

TECHNICAL DATA

POWERCLOSE

A S S U R I T Y

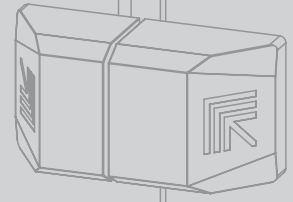

DOOR/GATE SPECIFICATION

The PowerClose has been tested with the following door/gate specifications

Size: 35in (W) x 82in (H)

Max. Weight: 100 lbs

Closing strength: 4lbs (*@ tongue)

*The closing strength is measuring the magnetic pull at the latch tongue end. The strength needed to overcome resistant tongue/striker. Wider door/gates have a weaker closing strength and the opposite for narrower doors/gates (see diagram below)

Should your door/gate be **heavier**, then an additional Powerclose Kit might be required to get the final snap close.

Should your door/gate be **lighter**, then there is the option of adjusting one of the magnets to be slightly further away (see install instructions) which will reduce the magnetic force in the **POWERCLOSE ZONE**

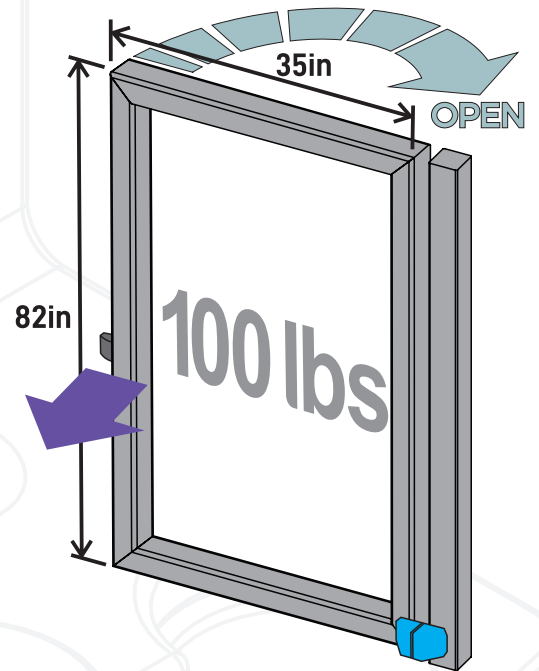

PERFORMANCE DIAGRAM

FAST SWING ZONE

HINGE SPRINGS ACCELERATE THE CLOSING ACTION

SLOW SWING ZONE

DAMPERS SLOW DOWN THE CLOSING SPEED

POWERCLOSE ZONE

MAGNETIC FORCES FOR THE FINAL SNAP CLOSE

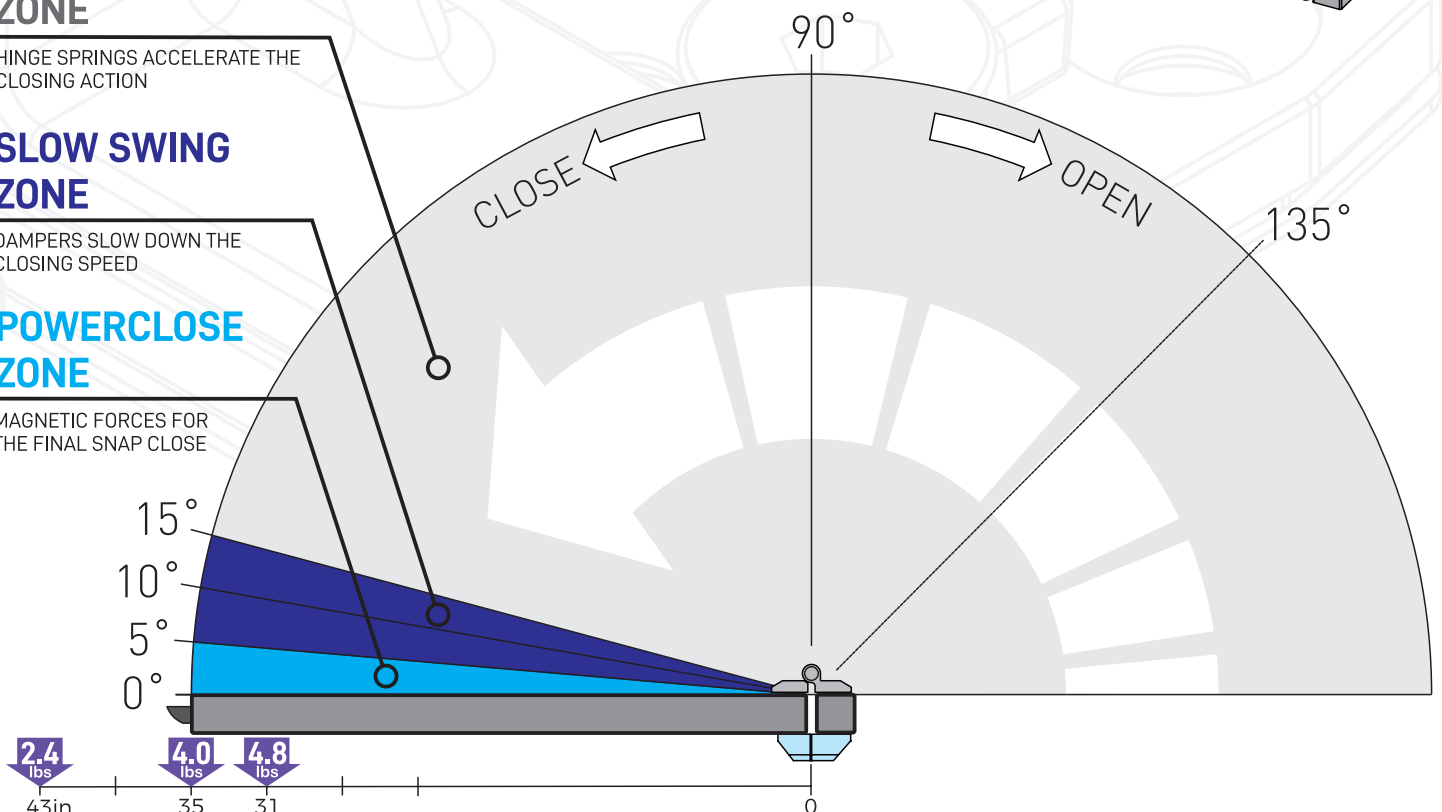

Our Team at Glass Hardware Australia can assist should you have any queries

Also, check our technical support videos on [YouTube @PolarisSoftCloseHinge](#)